

# AXE Microprocess Rate & Totalizer Controller Meter PULSE INPUT MFRT-S series

## FEATURES

- ⊙ Accept pulse(NPN/PNP)or magnetic pick up(>30mV), ⊙16BIT DAC analog output can be modified finish totalizer and control function
- ⊙ Accuracy 0.03% F.S.±1 digit
- ⊙ Rate display range 0 to 99999 can be modified
- ⊙ Totalizer display range 0 to 99999999
- ⊙ Input range 0.01Hz~10KHz
- ⊙ Rate and Totalizer decimal point can be modified
- ⊙ Totalizer timebase can be modified(1/60/3600sec)
- ⊙ Scale can be modified(0.00001 to 9999.9999)
- ⊙ Totalizer over automatic reset(RESET)
- ⊙ Totalizer can be stop count by terminal(GATE)
- ⊙ Display average can be modified(1~99)
- ⊙ BAUD RATE:19200/9600/4800/2400
- ⊙ 0.374" highlight display
- ⊙ Man-machine interface,easy to operate
- ⊙ EEPROM Saving ,data safekeeping about 10 years
- ⊙ Modified inside parameter ,must have pass code
- ⊙ Dual alarm function
- ⊙ Power down saving
- ⊙ Exciting supply DC24V,<25mA

## Name of Parts

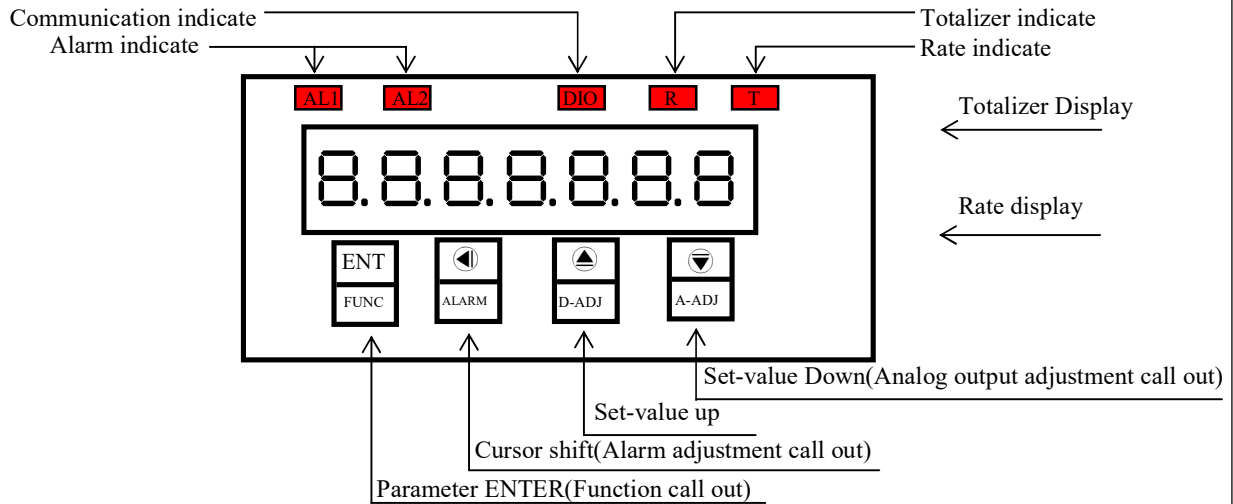

## Connect Diagram

### ⊙ Contact input(PNP)

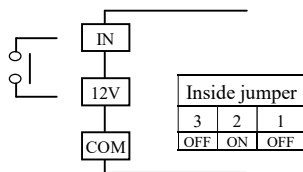

### ⊙ CMOS input(12V or 15V)

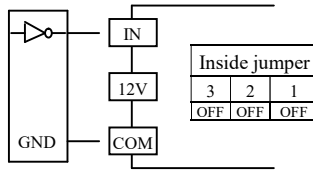

### ⊙ Sensor input(PNP 12V)

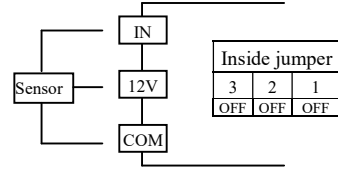

### ⊙ Contact input(NPN)

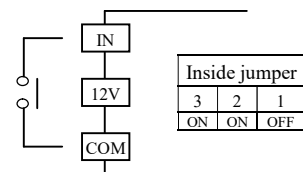

### ⊙ TTL input(5V)

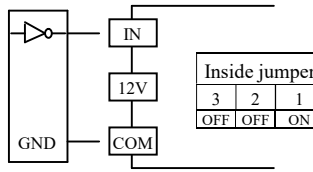

### ⊙ Sensor input(NPN 12V)

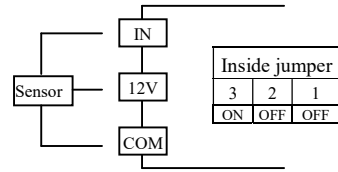

## Input function jumper table

3	□ □	Position 3	ON: TTL	OFF:CMOS
2	□ □	Position 2	ON: 0~50Hz	OFF:0~10KHz
1	□ □	Position 1	ON: NPN	OFF:PNP

Key Introduce		Operation Manual	
☺ Key Function		1.In normal display,The key function is call out setting group 2.In parameter setting page,The key function is data Enter , and goto next page	
◀ Key Function		1.In normal display,The key function is call out alarm value setting page 2.Into parameter setting page,the parameter mark&data is alternate display,If need modify data can press shift key into setting procedure,The display is lock parameter data,this time must let off key about 0.2 sec,press again,the cursor(twinkle express)is cycle moving left. (Key Response about 0.2 sec)	
▲ Key Function		1.Into parameter setting page,the parameter mark&data is alternate display,If need modify data can press up key into setting procedure,The display is lock parameter data,this time must let off key about 0.2 sec,press again,the parameter data will increment. (Key Response about 0.2 sec)	
▼ Key Function		1.In normal display,The key function is call out adjustment analog output ZERO&SPAN page 2.Into parameter setting page,the parameter mark&data is alternate display,If need modify data can press down key into setting procedure,The display is lock parameter data,this time must let off key about 0.2 sec,press again the parameter data will decrement. (Key Response about 0.2 sec)	
▲&▼ Key Function		In setting group or setting page press ▲&▼ key return normal display,but if in setting page the modify data will be lost	
No Key in anything		In setting group or setting page no key in anything about 2 minutes,return normal display,but if in Setting page the modify data will be lost	
Step	Parameter Mark Description	Parameter Mark	Operation Manual
1	Normal display	1 2 3 4 5 7 8 1 2 3 4 5	Press ☺ key into P.COD setting page
2	SYS(System setting group)	5 5 5	1. Select setting group with ◀ key 2. Press ☺ key into setting page of selection setting group
3	ROP(Alarm setting group)	r o p	
4	AOP(Analog output setting group)	A o p	
5	DOP(Communication setting group)	d o p	
3	SYS(System setting group)	5 5 5	
3-1	DPR(Decimal Point Rate setting page)Default=0	0 d P r	1. Decide rate decimal point position with ▲&▼ key(0 to 4) 2. Press ☺ key enter data and into DSPH setting page
3-2	DSPH(Display High Scale setting page)Default=19999	9 9 9 9 9 d S P H	1.Decide rate display high scale with ◀&▲&▼ key(0 to 19999) 2.Press ☺ key enter data and into INHI setting page
3-3	INHI(Input Max. Hz ) Default=9999.99	9 9 9 9 9 9 . n H z	1.Decide input max. Hz with ◀&▲&▼ key(0.01 to 9999.99Hz) 2.Press ☺ key enter data and into AVG setting page
3-4	LCUT (Low Cut) Default=0	0 L C U T	1. Decide display low cut with ◀&▲&▼ key (0~99) 2. Press ☺ key enter data and into DPT setting page
3-5	AVG (Dispaly Average time setting page)Default=5	5 5 A V G	1.Decide display average times with ◀&▲&▼ key(1 to 99) 2.Press ☺ key enter data and into TBASE setting page
3-6	DPT (Decimal Point Totalizer setting page)Default=0	0 d P T	1.Decide totalizer decimal point position with ▲&▼ key(0 to 8) 2.Press ☺ key enter data and into C.TIME setting page
3-7	C.TIME (Count Time) Default=1	1 C . T I M E	1.Decide C.TIME with ▲&▼ key(1/60/3600 sec) 2.Press ☺ key enter data and into SCALE setting page
3-8	SCALE (Scale to totalize setting page)Default=1	0 0 1 0 0 0 0 0 S C A L E	1.Decide Totalize scale with ◀&▲&▼ key(0.00001 to 9999.9999) 2.Press ☺ key enter data and into CODE setting page
3-9	CODE(Pass Code setting page)Default=0	0 0 0 0 0 0 C O D E	1.Decide pass code with ◀&▲&▼ key(0 to 99999) 2.Press ☺ key enter data and into LOCK setting page
3-10	LOCK(Panel Lock setting page)Default=NO	n o L O C K	1.Decide panel lock with ▲&▼ key(NO or YES) 2.Press ☺ key enter data and return SYS setting group
3-11	SYS(System setting group)	5 5 5	Press ◀ key decide SYS setting group,press ☺ key into DPR setting page

4	ROP(Alarm setting group)		Press ◀ key decide ROP setting group,press Ⓜ key into AL.SEL setting page
4-1	AL.SEL(Alarm Select setting page)Default=RATE	ROP RATE ALSEL	1.Decide Alarm select with ▲&▼ key(RATE or TOTALIZER) 2.Press Ⓜ key enter data and into ACT1 setting page
4-2	ACT1(Alarm Active 1 setting page)Default=HI	HI ACT1	1.Decide Alarm active 1 with ▲&▼ key(HI or LO) 2.Press Ⓜ key enter data and into ACT2 setting page
4-3	ACT2(Alarm Active 2 setting page)Default=HI	HI ACT2	1.Decide Alarm active 2 with ▲&▼ key(HI or LO) 2.Press Ⓜ key enter data and return ROP setting group
4-4	DEL1(Alarm Delay 1 setting page)Default=0	00 DEL1	1.Decide Alarm delay 1with ◀&▲&▼ key(0~99 sec) 2.Press Ⓜ key enter data and into DEL2 setting page
4-5	DEL2(Alarm Delay 2 setting page)Default=0	00 DEL2	1.Decide Alarm delay 1with ◀&▲&▼ key(0~99 sec) 2.Press Ⓜ key enter data and into DEL2 setting page
4-6	ROP(Alarm setting group)	ROP	Press ◀ key decide ROP setting group,press Ⓜ key into AL.SEL setting page
5	AOP(Analog output setting group)	AOP	Press ◀ key decide AOP setting group,press Ⓜ key into AO.SEL setting page
5-1	AO.SEL(Analog Output Select setting page)Default=RATE	RATE AOSSEL	1.Decide Analog output select with ▲&▼ key(RATE or TOTALIZER) 2.Press Ⓜ key enter data and into ANLO setting page
5-2	ANLO(A/O Zero According to Display setting page)Default=0	00000000 ANLO	1.Decide ANLO with ◀&▲&▼ key (0~999999999) 2.Press Ⓜ key enter data and into ANHI setting page
5-3	ANHI(A/O Span According to Display setting page)Default=19999	00000000 ANHI	1.Decide ANHI with ◀&▲&▼ key(0~999999999) 2.Press Ⓜ key enter data and return AOP setting group
5-4	AOP(Analog output setting group)	AOP	Press ◀ key decide AOP setting group,press Ⓜ key into AO.SEL setting page
6	DOP(Communication setting group)	DOP	Press ◀ key decide DOP setting group,press Ⓜ key into ADDR setting page
6-1	ADDR(Communication -- Address setting page )Default=0	000 ADDR	1.Decide Communication address with ◀&▲&▼ key(0~255) 2.Press Ⓜ key enter data and into BAUD setting page
6-2	BAUD(Communication Baud Rate setting page)Default=19200	19200 BAUD	1.Decide baud rate with ▲&▼ key(19200,9600,4800,2400) 2.Press Ⓜ key enter data and into PARI setting page
6-3	PARI(Communication Parity Check setting page)Default=n.8.2	n.8.2 PARI	1.Decide parity check with ▲&▼ key(n82,n81,even,odd) 2.Press Ⓜ key enter data and return DOP setting group
6-4	DOP(Communication setting group)	DOP	Press ◀ key decide DOP setting group,press Ⓜ key into ADDR setting page
Step	Parameter Mark Description	Parameter Mark	Operation Manual
7	Normal display	1234578 12345	Press ◀ key about 3 sec.,into AL1 setting page
7-1	AL1 (Alarm value 1 setting page) Default=0	00000000 AL1	1.Decide Alarm value 1 with ◀&▲&▼ key(0 to 999999999) 2.Press Ⓜ key enter data and into AL2 setting page
7-2	AL2 (Alarm value 2 setting page) Default=0	00000000 AL2	1.Decide Alarm value 2 with ◀&▲&▼ key(0 to 999999999) 2.Press Ⓜ key enter data and return normal display
8	Normal display	1234578 12345	Press ▼ key about 3 sec.,into AZERO adjustment page
8-1	AZERO(Analog Output Zero Adjustment page)Default=0	00000000 AZERO	1.Adjustment analog output zero with ◀&▲&▼ key(±6000) 2.Press Ⓜ key enter data and into ASPAN adjustment page
8-2	ASPAN(Analog Output Span Adjustment page)Default=0	00000000 ASPAN	1.Adjustment analog output span with ◀&▲&▼ key(±6000) 2.Press Ⓜ key enter data and return normal display

Appendix	Error Mark Description	Error Mark	Analyze & Description
1	Input over error detect	1234578	Input frequency over range(10KHz)
		□FL	
2	Display over error detect	1234578	Display over range(99999)
3	EEPROM error detect	□□	1.External interference when EEPROM read/write 2.EEPROM write over 1 million times(guarantee 10 years) Please power reset,if still display E-00,doing following step: 1.E-00 & No alternate display for inquire reset EEPROM 2.Decide Yes with or key,press key return normal display 3.EEPROM was reset,Please follow step 1~10 set again
		E-00	
		YES	
		E-00	

## MFRT Modbus RTU Mode Protocol Address Map

DATA Format 16Bit/32Bit,sign bit

8000~7FFF( -32768~32767 )/80000000~7FFFFFFF(-2147483648~2147483647)

Address	Name	Description	Accept
0000	PARI	Bit 0 and 1,Communication Parity Check,Input range 00:N82, 01:N81, 10:EVEN, 11:ODD	R/W
	BAUD	Bit 2 and 3,Communication Baud Rate,Input range 00:19200, 01:9600, 10:4800, 11:2400	R/W
	ALSEL	Bit 4 Alarm Select ,Input range 0:RATE,1:TOTAL	R/W
	LOCK	Bit 5 Panel Lock,Input range 0:NO,1:YES	R/W
	ACT1	Bit 6 Alarm Active 1 ,Input range 0:HI,1:LO	R/W
	ACT2	Bit 7 Alarm Active 1 ,Input range 0:HI,1:LO	R/W
0001	DPR	Decimal Point Rate,Input range 000:10 <sup>0</sup> ,001:10 <sup>-1</sup> ,010:10 <sup>-2</sup> ,011:10 <sup>-3</sup> ,100:10 <sup>-4</sup>	R/W
	AOSEL	Analog Output Select ,Input range 0:RATE,1:TOTAL	R/W
	DPT	Decimal Point Totalizer,Input range 000:10 <sup>0</sup> ,001:10 <sup>-1</sup> ,010:10 <sup>-2</sup> ,011:10 <sup>-3</sup> ,100:10 <sup>-4</sup> ,101:10 <sup>-5</sup> ,110:10 <sup>-6</sup> ,111:10 <sup>-7</sup>	R/W
0002	AVG	Dispaly Average time,Input range 0001~0063(1~99)	R/W
0004	ADDR	Communication Address ,Input range 0000~00FF(0~255)	R/W
0006	CTIME	Count Time,Input range 0000~0002(0~2)0:1,1:60,2:3600 sec.	R/W
000C	DEL1	Alarm delay 1,Input range 0000~0063(0~99)	R/W
000E	DEL2	Alarm delay 2,Input range 0000~0063(0~99)	R/W
0010	LCUT	Display Low Cut ,Input range 0000~03E7(0~999)	R/W
0012	INHI	Input Max. Hz ,Input range 00000001~000F423F(1~999999)	R/W
0016	DSPH	Display High Scale,Input range 00000000~0001869F (0~99999)	R/W
001A	CODE	Pass Code,Input range 00000000~0001869F(0~99999)	R/W
001E	SCALE	Scale to totalize ,Input range 00000000~05F5E0FF (0~99999999)	R/W
0022	AL1	Alarm value 2 ,Input range 00000000~05F5E0FF (0~99999999)	R/W
0026	AL2	Alarm value 1 ,Input range 00000000~05F5E0FF (0~99999999)	R/W
002A	ANLO	A/O Zero According to Display ,Input range 00000000~05F5E0FF (0~99999999)	R/W
002E	ANHI	A/O Span According to Display .Input range 00000000~05F5E0FF (0~99999999)	R/W
0032	AZERO	Analog Output Zero Adjustment ,Input range E890~1770(-6000~6000)	R/W
0034	ASPAN	Analog Output Span Adjustment ,Input range E890~1770(-6000~6000)	R/W
003A	TOTAL	Totalizer Display,Display range 00000000~05F5E0FF (0~99999999))	R
003E	RATE	Rate Display,Display range 00000000~0001869F (0~99999)	R