

■ Features

- ◎Dual input measuring & display (Potentiometer/Transmitter/RTD/Loadcell)
- ◎Accuracy 0.05% F.S.±1 digit
- ◎Display range -19999~19999 can be modified
- ◎Decimal point can be modified
- ◎Per input have 2 Alarm function
- ◎Display average can be modified(1~99)
- ◎16BIT DAC analog output can be modified
- ◎RS485communication interface,Photocol MODBUS RTU MODE
- ◎BAUD RATE:19200/9600/4800/2400
- ◎0.4" highlight display
- ◎Man-machine interface ,easy to operate
- ◎EEPROM Saving,data safekeeping about 10 years

■ Name Of Parts

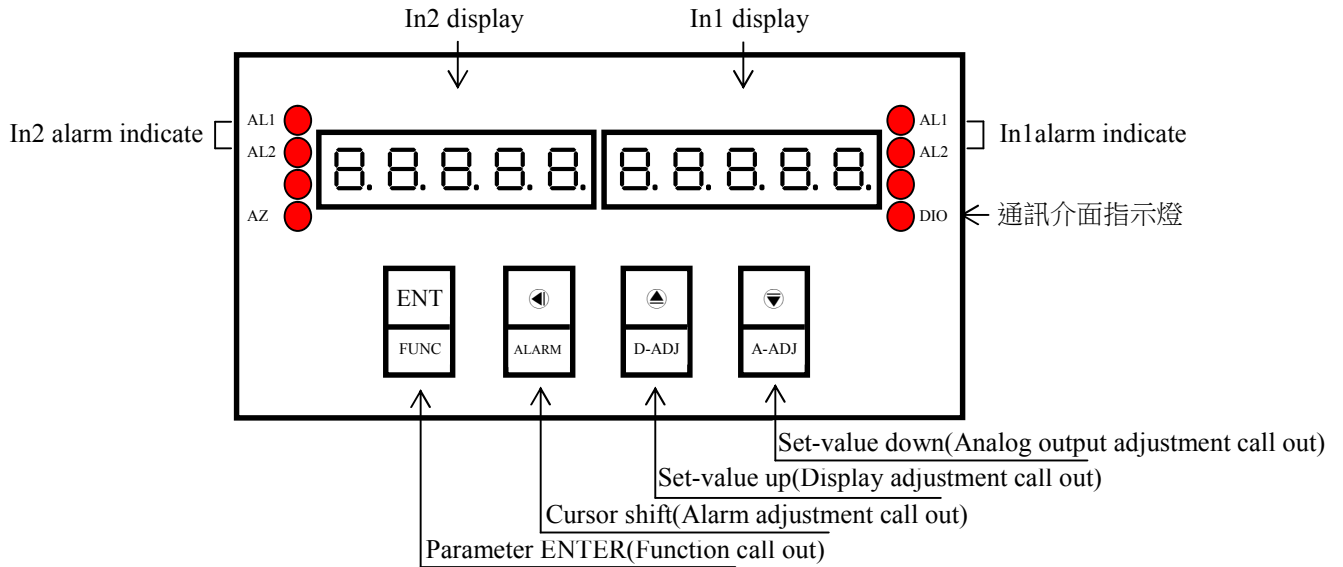

| Key Introduce | Operation Manual |
|--------------------|---|
| Ⓜ Key Function | 1.In normal display,The key function is call out setting group 2.In parameter setting page,The key function is data Enter , and goto next page |
| ◀ Key Function | 1.In normal display,The key function is call out alarm value setting page 2.Into parameter setting page,the parameter mark&data is alternate display,If need modify data can press shift key into setting procedure,The display is lock parameter data,this time must let off key about 0.2 sec,press again,the cursor(twinkle express)is cycle moving left. (Key Response about 0.2 sec) |
| ▲ Key Function | 1.In normal display,The key function is call out adjustment display value (DZERO&DSPAN)page 2.Into parameter setting page,the parameter mark&data is alternate display,If need modify data can press up key into setting procedure,The display is lock parameter data,this time must let off key about 0.2 sec,press again,the parameter data will increment. (Key Response about 0.2 sec) |
| ▼ Key Function | 1.In normal display,The key function is call out adjustment analog output (AZERO&ASpan)page 2.Into parameter setting page,the parameter mark&data is alternate display,If need modify data can press down key into setting procedure,The display is lock parameter data,this time must let off key about 0.2 sec,press again the parameter data will decrement. (Key Response about 0.2 sec) |
| ▲&▼ Key Function | In setting group or setting page press ▲&▼ key return normal display,but if in setting page the modify data will be lost |
| No Key in anything | In setting group or setting page no key in anything about 2 minutes,return normal display,but if in Setting page the modify data will be lost |

| Step | Parameter Mark Description | Parameter Mark | Operation Manual |
|------|-----------------------------|----------------|--|
| 1 | Normal display | 1 2 3 4 5 | Press Ⓜ/FUNC key into P.COD setting page |
| 2 | P.COD(Pass code input page) | P.C o d | 1.Key in 5 digit pass code with ◀ or ▲ or ▼ key 2.Press Ⓜ key,the pass code is right into setting group , otherwise return normal display |
| | | □ □ □ □ □ | |

| | | | |
|------|--|------------------------|--|
| 3 | SYS(System setting group) | S Y S | 1. Select setting group with ◀ key |
| | ROP(Alarm setting group) | r o P | 2. Press Ⓜ key into setting page of selection setting group |
| | AOP(Analog output setting group) | A o P | |
| | DOP(Communication setting group) | d o P | |
| 4 | SYS(System setting group) | S Y S | Press ◀ key decide SYS setting group , press Ⓜ key into DP1 setting page |
| 4-1 | DP1(Decimal Point 1) Default=0 | d P 1 □ | 1. Decide decimal point 1 position with ▲ or ▼ key (0 to 4) 2. Press Ⓜ key enter data and into DSPL1 setting page |
| 4-2 | DSPL1(Display1 Low Scale) Default=0 | d S P L 1 □ □ □ □ | 1. Decide display1 low scale with ◀&▲&▼ key (-19999~19999) 2. Press Ⓜ key enter data and into DSPH1 setting page |
| 4-3 | DSPH1(Display1 High Scale) Default=19999 | d S P H 1 1 9 9 9 9 | 1. Decide display1 high scale with ◀&▲&▼ key (-19999~19999) 2. Press Ⓜ key enter data and into DP2 setting page |
| 4-4 | DP2(Decimal Point 2) Default=0 | d P 2 □ | 3. Decide decimal point 2 position with ▲ or ▼ key (0 to 4) 4. Press Ⓜ key enter data and into DSPL2 setting page |
| 4-5 | DSPL2(Display2 Low Scale) Default=0 | d S P L 2 □ □ □ □ | 1. Decide display2 low scale with ◀&▲&▼ key (-19999~19999) 2. Press Ⓜ key enter data and into DSPH2 setting page |
| 4-6 | DSPH2(Display2 High Scale) Default=19999 | d S P H 2 1 9 9 9 9 | 1. Decide display2 high scale with ◀&▲&▼ key (-19999~19999) 2. Press Ⓜ key enter data and into AVG setting page |
| 4-7 | AVG (Average) Default=5 | A v G □ □ □ □ | 1. Decide display Average times with ◀&▲&▼ key (1~99) 2. Press Ⓜ key enter data and into LCUT setting page |
| 4-8 | LCUT (Low Cut) Default=0 | L C U T □ □ □ □ | 1. Decide display low cut with ◀&▲&▼ key (0~99) 2. Press Ⓜ key enter data and into CODE setting page |
| 4-9 | CODE(Pass Code) Default=0 | C o d e □ □ □ □ | 1. Decide Pass code with ◀&▲&▼ key (0~19999) 2. Press Ⓜ key enter data and into LOCK setting page |
| 4-10 | LOCK(Panel Lock) Default=NO | L o c k n o | 1. Decide panel lock with ▲ or ▼ key (NO or YES) 2. Press Ⓜ key enter data and into AZ.SEL setting page |
| 4-11 | AZ.SEL(AZ select) Default=IN12 | A Z . S E L i n 1 2 | 1. Decide AZ select with ▲ or ▼ key (IN12 or IN1 or IN2) 2. Press Ⓜ key enter data and return SYS setting group |
| 5 | ROP(Alarm setting group) | r o P | Press ◀ key decide ROP setting group, press Ⓜ key into ACT11 setting page |
| 5-1 | ACT11(IN1 Alarm Active1 setting page) Default=HI | A C T 1 1 H , | 1. Decide IN1 active 1 with ▲ or ▼ key(HI or LO) 2. Press Ⓜ key enter data and into ACT12 setting page |
| 5-2 | ACT12(IN1 Alarm Active2 setting page) Default=HI | A C T 1 2 H , | 1. Decide IN1 active 2 with ▲ or ▼ key(HI or LO) 2. Press Ⓜ key enter data and into ACT21 setting page |
| 5-3 | ACT21(IN2 Alarm Active1 setting page) Default=HI | A C T 2 1 H , | 1. Decide IN2 active 1 with ▲ or ▼ key(HI or LO) 2. Press Ⓜ key enter data and into ACT22 setting page |
| 5-4 | ACT22(IN2 Alarm Active2 setting page) Default=HI | A C T 2 2 H , | 1. Decide IN2 active 2 with ▲ or ▼ key(HI or LO) 2. Press Ⓜ key enter data and into HYS11 setting page |
| 5-5 | HYS11(IN1 Alarm Hysteresis1 setting page) Default=0 | H Y S 1 1 □ □ □ □ | 1. Decide IN1 Hysteresis 1 with ◀ or ▲ or ▼ key(0~999) 2. Press Ⓜ key enter data and into HYS12 setting page |
| 5-6 | HYS12(IN1 Alarm Hysteresis2 setting page) Default=0 | H Y S 1 2 □ □ □ □ | 1. Decide IN1 Hysteresis 2 with ◀ or ▲ or ▼ key(0~999) 2. Press Ⓜ key enter data and into HYS21 setting page |
| 5-7 | HYS21(IN2 Alarm Hysteresis1 setting page) Default=0 | H Y S 2 1 □ □ □ □ | 1. Decide IN2 Hysteresis 1 with ◀ or ▲ or ▼ key(0~999) 2. Press Ⓜ key enter data and into HYS22 setting page |
| 5-8 | HYS22(IN2 Alarm Hysteresis2 setting page) Default=0 | H Y S 2 2 □ □ □ □ | 1. Decide IN2 Hysteresis 2 with ◀ or ▲ or ▼ key(0~999) 2. Press Ⓜ key enter data and return ROP setting group |

| | | | |
|------|---|------------------------|--|
| 6 | AOP(Analog output setting group) | A O P | Press ◀ key decide AOP setting group , press Ⓜ key into AO.SEL setting page |
| 6-1 | AO.SEL(Analog Output Select) Default=IN1 | A O S E L I N 1 | 1.Decide AO.SEL with ▲ or ▼ key(IN1 or IN2 or 1ADD2 or 1SUB2 or 1MUL2 or 1DIV2) 2.Press Ⓜ key enter data and into ANLO setting page |
| 6-2 | ANLO(A/O Zero According to Display setting page)Default=0 | A N L O 0 0 0 0 0 | 1.Decide ANLO with ◀ or ▲ or ▼ key(-19999~19999) 2.Press Ⓜ key enter data and into ANHI setting page |
| 6-3 | ANHI(A/O Span According to Display setting page)Default=0 | A N H I 1 9 9 9 9 | 1.Decide ANHI with ◀ or ▲ or ▼ key(-19999~19999) 2.Press Ⓜ key enter data and return AOP setting group |
| 7 | DOP(Communication setting group) | d o P | press ◀ key decide DOP setting group,press Ⓜ key into ADDR setting page |
| 7-1 | ADDR(Communication –Address setting page) Default=0 | A d d r 0 0 0 0 0 | 1.Decide address with ◀ or ▲ or ▼ key(0~255) 2.Press Ⓜ key enter data and into BAUD setting page |
| 7-2 | BAUD(Communication Baud Rate setting page)Value on Default=19200 | b A U D 1 9 2 0 0 | 1.Decide baud rate with ▲ or ▼ key(19200,9600,4800,2400) 2.Press Ⓜ key enter data and into PARI setting page |
| 7-3 | PARI(Communication Parity Check setting page)Default=n82 | P A R I n . 8 . 2 | 1.Decide parity check with ▲ or ▼ key(n82,n81,even,odd) 2.Press Ⓜ key enter data and return DOP setting group |
| Step | Parameter mark description | Parameter mark | Operation manual |
| 8 | Normal display | 1 2 3 4 5 | Press ◀/ALARM key about 3 sec,into AL11 setting page |
| 8-1 | AL11 (IN1 Alarm value 1 setting page) Default=0 | A L 1 1 0 0 0 0 0 | 1.Decide IN1 alarm value 1 with ◀ or ▲ or ▼ key(+/-19999) 2.Press Ⓜ key enter data and into AL12 setting page |
| 8-2 | AL12 (IN1 Alarm value 2 setting page) Default=0 | A L 1 2 0 0 0 0 0 | 1.Decide IN1 alarm value 2 with ◀ or ▲ or ▼ key(+/-19999) 2.Press Ⓜ key enter data and into AL21 setting page |
| 8-3 | AL21 (IN2 Alarm value 1 setting page) Default=0 | A L 2 1 0 0 0 0 0 | 1.Decide IN2 alarm value 1 with ◀ or ▲ or ▼ key(+/-19999) 2.Press Ⓜ key enter data and into AL22 setting page |
| 8-4 | AL22 (IN2 Alarm value 2 setting page) Default=0 | A L 2 2 0 0 0 0 0 | 1.Decide IN2 alarm value 2 with ◀ or ▲ or ▼ key(+/-19999) 2.Press Ⓜ key enter data and return normal display |
| Step | Parameter mark description | Parameter mark | Operation manual |
| 9 | Normal display | 1 2 3 4 5 | Press ▼/A-ADJkey about 3 sec,into DZER1 adjustment page |
| 9-1 | DZER1(IN1 Display Zero Adjust)預設值為 0 | d Z E R 1 0 0 0 0 0 | 1.IN1 Adjustment display zero with ▲ or ▼ key 2.Press Ⓜ key enter data and into DSPA1 adjustment page |
| 9-2 | DSPA1(IN1 Display Span Adjust)預設值為 0 | d S P A 1 0 0 0 0 0 | 1.IN1 Adjustment display span with ▲ or ▼ key 2.Press Ⓜ key enter data and into DZER2 adjustment page |
| 9-3 | DZER2(IN2 Display Zero Adjust)預設值為 0 | d Z E R 2 0 0 0 0 0 | 1.IN2 Adjustment display zero with ▲ or ▼ key 2.Press Ⓜ key enter data and into DSPA2 adjustment page |
| 9-4 | DSPA2(IN2 Display Span Adjust)預設值為 0 | d S P A 2 0 0 0 0 0 | 1.IN2 Adjustment display span with ▲ or ▼ key 2.Press Ⓜ key enter data and return normal display |
| Step | Parameter mark description | Parameter mark | Operation manual |
| 10 | Normal display | 1 2 3 4 5 | Press ▼/A-ADJkey about 3 sec,into AZERO adjustment page |
| 10-1 | AZERO(Analog Output Zero Adjustment page) Value on EEPROM reset=0 | A Z E R O 0 0 0 0 0 | 1.Adjustment analog output zero with ◀ or ▲ or ▼ key(±6000) 2.Press Ⓜ key enter data and into ASPAN adjustment page |
| 10-2 | ASPAN(Analog Output Span Adjustment page) Value on EEPROM reset=0 | A S P A N 0 0 0 0 0 | 1.Adjustment analog output span with ◀ or ▲ or ▼ key(±6000) 2.Press Ⓜ key enter data and return normal display |

| Appendix | Error Mark Description | Error Mark | Analyze & Description |
|----------|----------------------------|------------|--|
| 1 | Input over error detect | . 0 FL | Input signal over range(120%) |
| 2 | Input under error detect | - . 0 FL | Input signal under range(-20%) |
| 3 | Display over error detect | d 0 FL | Display over range(19999) |
| 4 | Display under error detect | - d 0 FL | Display under range(-19999) |
| 5 | A/D Converter error detect | ADER | 1.Input signal over range (180%) 2.Inside circuit damage Please moving input signal if still display ADER,please contact us |
| 6 | EEPROM error detect | E - 00 | 1.External interference when EEPROM read/write |
| | | 00 | 2.EEPROM write over 100 million times(guarantee 10 years) |
| | | YES | Please power reset,if still display E-00,doing following step: 1.E-00 & No alternate display for inquire reset EEPROM 2.Decide Yes with ▲ or ▼ key,press Ⓜ key return normal display 3.EEPROM was reset,Please follow step 1~10 set again |

MM2D Modbus RTU Mode Protocol Address Map

Data format 16/32Bit, sign bit 8000~7FFF(-32768~32767)/80000000~7FFFFFFF(-2147483648~2147483647)

| Address | Name | Description | Accept |
|---------|--------|--|--------|
| 0000 | DSPL1 | DSPL1, input range B1E1~4E1F(-19999~19999) | R/W |
| 0002 | DSPH1 | DSPH1, input range B1E1~4E1F(-19999~19999) | R/W |
| 0004 | DSPL2 | DSPL2, input range B1E1~4E1F(-19999~19999) | R/W |
| 0006 | DSPH2 | DSPH2, input range B1E1~4E1F(-19999~19999) | R/W |
| 0008 | AVG | AVG, input range 0001~0063(1~99) | R/W |
| 000A | LCUT | LCUT, input range 0000~0063(0~99) | R/W |
| 000C | CODE | CODE, input range 0000~4E1F(0~19999) | R/W |
| 000E | HYS11 | HYS11, input range 0000~03E7(0~999) | R/W |
| 0010 | HYS12 | HYS12, input range 0000~03E7(0~999) | R/W |
| 0012 | HYS21 | HYS21, input range 0000~03E7(0~999) | R/W |
| 0014 | HYS22 | HYS22, input range 0000~03E7(0~999) | R/W |
| 0016 | AL11 | AL11, input range B1E1~4E1F(-19999~19999) | R/W |
| 0018 | AL12 | AL12, input range B1E1~4E1F(-19999~19999) | R/W |
| 001A | AL21 | AL21, input range B1E1~4E1F(-19999~19999) | R/W |
| 001C | AL22 | AL22, input range B1E1~4E1F(-19999~19999) | R/W |
| 001E | AO.SEL | AO.SEL, input range 0000~0005(0~5)0:IN1, 1:IN2, 3:1SUB2, 4:1MUL2, 5:1DIV2 | R/W |
| 0020 | ANLO | ANLO, input range B1E1~4E1F(-19999~19999) | R/W |
| 0022 | ANHI | ANHI, input range B1E1~4E1F(-19999~19999) | R/W |
| 0024 | AZERO | AZERO, input range 1770~E890(-6000~6000) | R/W |
| 0026 | ASPAN | ASPAN, input range 1770~E890(-6000~6000) | R/W |
| 0028 | ADDR | ADDR, input range 0000~00FF(0~255) | R/W |
| 002A | BAUD | BAUD, input range 0000~0003(0~3)0:19200, 1:9600, 2:4800, 3:2400 | R/W |
| 002C | PARI | PARI, input range 0000~0003(0~3)0:N82, 1:N81, 2:EVEN, 3:ODD | R/W |
| 003E | DP | MSB=DP1, LSB=DP2 per BYTE input range 0~4 0:10 ⁰ , 1:10 ¹ , 2:10 ² , 3:10 ³ , 4:10 ⁴ | R/W |
| 0040 | STATUS | MSB BIT7:LOCK(1:YES 0:NO), BIT6:AZ(1:ON, 0:OFF) BIT1&BIT0:AZSEL(00:IN12, 01:IN1, 10:IN2) LSB BIT0:ACT11, BIT1:ACT12, BIT2:ACT21, BIT3:ACT22(0:HI, 1:LO) | R/W |
| 0042 | AZ1 | IN1 AZ value, range B1E1~4E1F(-19999~19999) | R |
| 0044 | AZ2 | IN2 AZ value, range B1E1~4E1F(-19999~19999) | R |
| 0046 | DISP1 | IN1 display value, range B1E1~4E1F(-19999~19999) | R |
| 0048 | DISP2 | IN2 display value, range B1E1~4E1F(-19999~19999) | R |