

AXE MICROPRESS 6 DIGITAL AUTOMATION ORIENT CONTROLLER COUNTER (72x72mm)

MCO726 Series

FEATURES

- ⊙ Accept input up to 5KHz(Quadra ture)
- ⊙ Readout Range from -19999~999999
- ⊙ Power down saving
- ⊙ Decimal point can be modified
- ⊙ Input scaling multiplied 0.0001 to 9.9999 can be modified
- ⊙ Orient counter value can be modified(-19999~999999)
- ⊙ Compare hysrsersis can be modified
- ⊙ Three relay output function(A>B,A=B,A<B)
- ⊙ 0.36" LED highlight display
- ⊙ Man-machine interface, easy to operate
- ⊙ EEPROM Saving, data safekeeping about 10 years
- ⊙ Modified inside parameter, must have pass code

Name of Parts

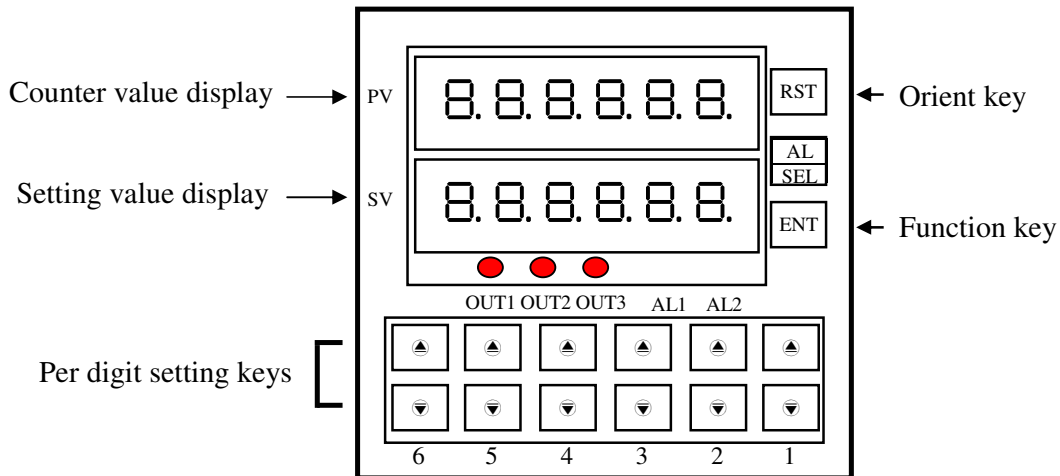

Connect Diagram

⊙ Contact input (PNP)

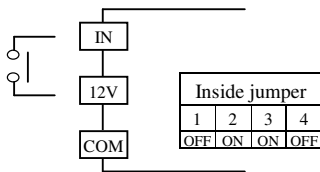

⊙ CMOS input (12V or 15V)

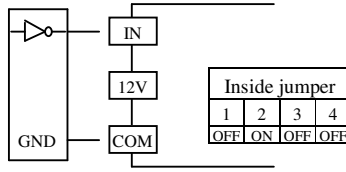

⊙ Sensor input (PNP 12V)

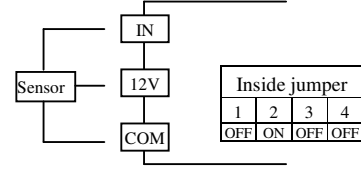

⊙ Contact input (NPN)

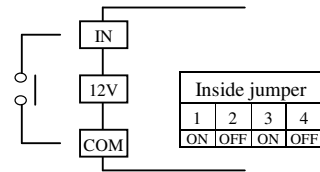

⊙ TTL input (5V)

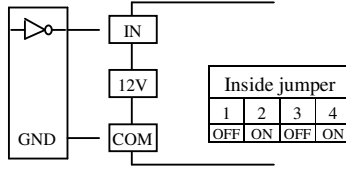

⊙ Sensor input (NPN 12V)

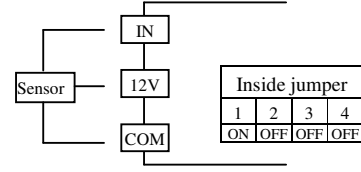

Output control mode description

- ⊙ Display value > Setting value + Hysteresis value HI(OUT1)Relay ON
- ⊙ Setting value + Hysteresis value ≥ Display value ≥ Setting value -Hysteresis value GO(OUT2) Relay ON
- ⊙ Display value < Setting - Hysteresis Value LO(OUT3) Relay ON
- ⊙ Press RST Orient key ,counter value return Orient counter value

Key Introduce		Operation Manual	
☼ Key Function		1. In normal display, The key function is call out setting group 2. In parameter setting page, The key function is data Enter , and go to next page	
RST Key Function		1.In any time, Press RST key, counter value return orient counter value	
Per digit▲/▼Key Function		1. In normal display, press per digit▲/▼key setting orient counter value 2. Into parameter setting page, If need modify data can press per digit▲/▼key into setting procedure ,The parameter data will increment /decrement. (Key Response about 0.2 sec)	
Digit 1▲/▼Key Function		In setting page press digit 1▲&▼key return normal display, but if in setting page the modify data will be lost	
No Key in anything		In setting group or setting page no key in anything about 2 minutes, return normal display	
Step	Parameter mark description	Parameter mark	Operation manual
1	Normal display	1 2 3 4 5 6	Press ☼/FUNC key into P.COD setting page
		1 2 3 4 5 6	
2	P.COD(Pass code input page) Default = 0	P . C o d	1. Key in 6 digit pass code with ◀&▲&▼ key 2. Press ☼ key into setting page of selection setting group
		0 0 0 0 0 0	
3	DP(Decimal Point) Default = 0	d P	1. Decide decimal point position with ▲&▼ key (0 to 5) 2. Press ☼ key enter data and into SCALE setting page
		0 0 0 0 0 0	
4	SCALE(Scale) Default = 0	S C A L E	1. Decide scale with ◀ & ▲ & ▼ key(0.00001~9.99999) 2 Press ☼ key enter data and into HYS setting page
		0.0 0 0 0 0 0	
5	HYS(Compare Hysteresis) Default = 0	H Y S	1.Press per digit 1~4▲&▼key input Hysteresis value (0~9999) 2. Press ☼ key enter data and into CODE setting page
		0 0 0 0 0 0	
6	CODE(Code) Default = 0	C o d E	1. Decide pass code with ◀ & ▲ & ▼ key(0~999999) 2. Press ☼ key enter data and into LOCK setting page
		0 0 0 0 0 0	
7	LOCK(Panel Lock) Default = NO	L o c k	1. Decide panel lock with ▲ & ▼ key(NO or YES) 2. Press ☼ key return setting page
		n o	
8	Setting alarm value Default = 0	1 2 3 4 5 6	1. Decide alarm value with per digit ▲& ▼ key(-199999~999999) 2. Non press any key about 5 sec,Auto save data
		1 2 3 4 5 6	
9	Setting Orient value Default = 0	o r i e n t	1.Press AL/SEL key 2.Decode orient value with per digit ▲& ▼ key(-199999~999999) 3.Non press any key about 5 sec,Auto save data
		1 2 3 4 5 6	