

FAIRCHILD

ELECTRO-PNEUMATIC I/P, E/P TRANSDUCER

Model T6000
Series

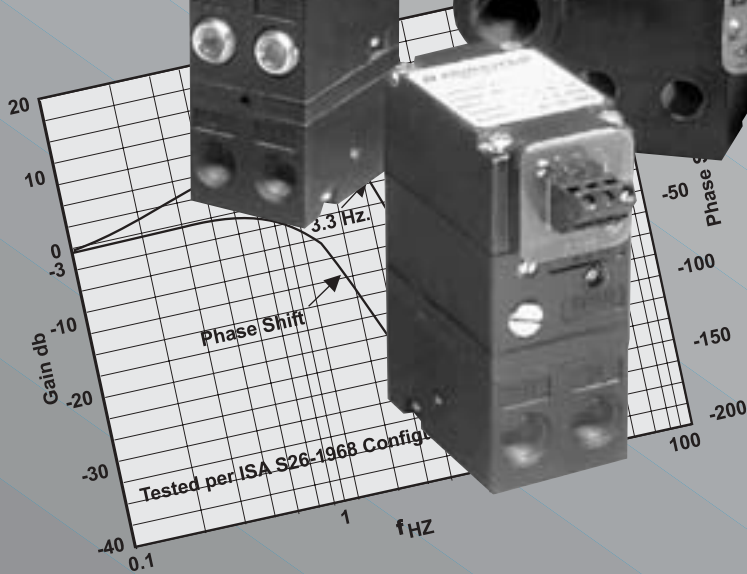
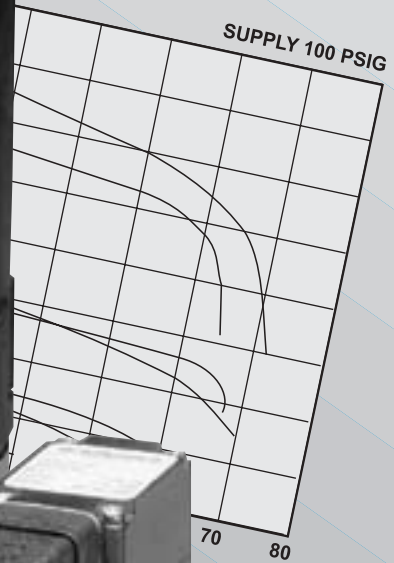
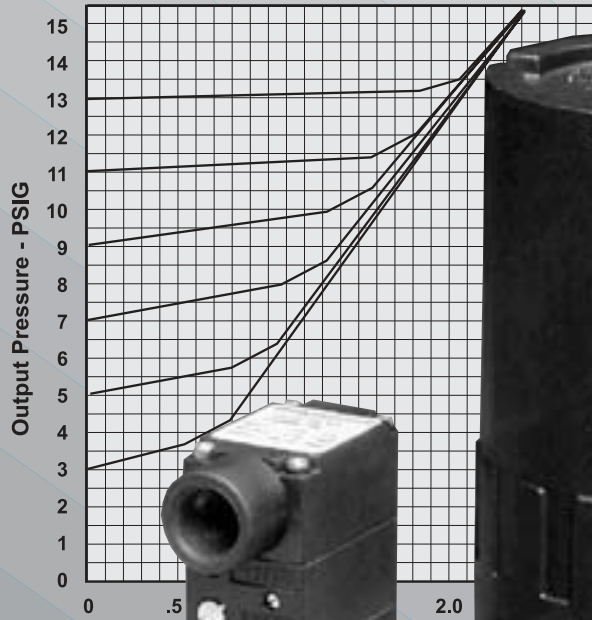

FAIRCHILD
INDUSTRIAL PRODUCTS COMPANY

T6000 SERIES TRANSDUCER

Electro-Pneumatic (I/P, E/P)

APPLICATIONS

The T6000 Series Electro-Pneumatic Transducer converts a DC current or voltage input signal to a directly proportional pneumatic output.

The T6000 Series is designed for precision applications, providing maximum versatility. The modular construction permits any basic unit to be used in the explosion-proof, rack, wall, pipe, panel, DIN rail or 3, 5, 10 or 15 unit manifold configurations. Servicing or calibration is quick and easy.

The compact size reduces weight and space requirements, simplifying the piping layout to the unit. External access to the restrictor orifice simplifies unit maintenance.

FEATURES

Performance

- Field Reversible Feature provides output which is directly or inversely proportional to the input signal.
- RFI/EMI Protection eliminates susceptibility to electromagnetic and radio interference.

Functional

- Six output pressure ranges meet final control element requirements.
- Six input signal ranges meet most process and machine requirements.

Physical

- Compact Size permits use in space restricted areas.
- Input and Output Ports on both front and rear simplifies pneumatic piping.
- Conduit Fitting, Terminal Strip or DIN Connectors allow easy wiring.
- Various Mounting Configurations allow installation flexibility for most applications.
- Explosion-Proof NEMA 4X, IP65, Type 4 Enclosure available for outdoor and indoor installations.
- External Zero and Span Adjustments on front for ease of calibration.

OUTLINE DIMENSIONS

Model TA6000 Standard Range

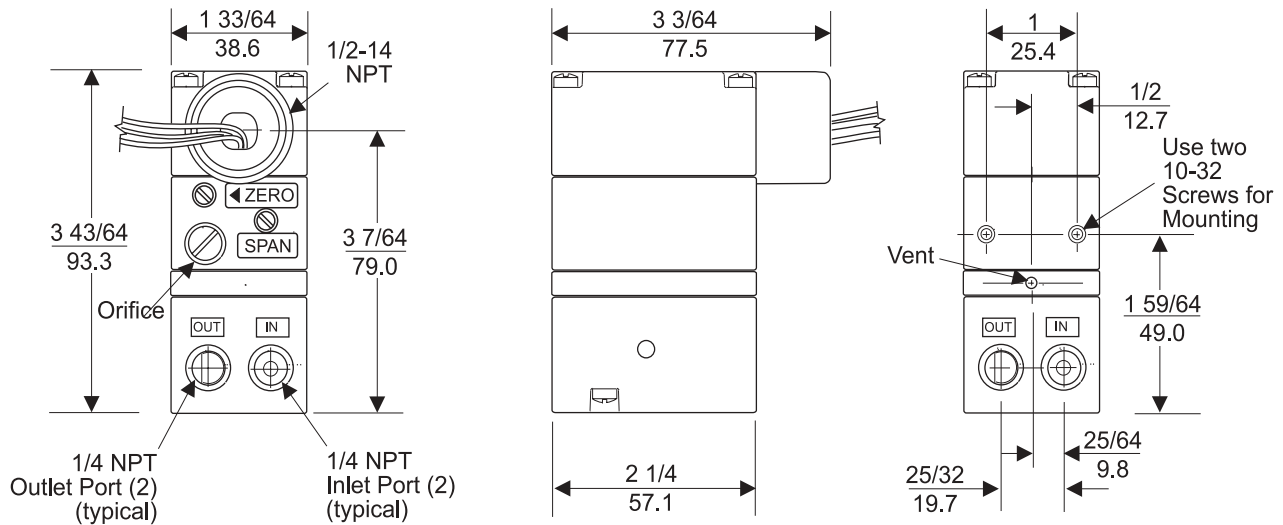

Figure 1. Model TA6000 Outline Dimensions.

STANDARD RANGE SPECIFICATIONS

FUNCTIONAL SPECIFICATIONS

Output Range	psig [BAR] (kPa)	3-15 [0.2-1.0] (20-100)	3-27 [0.2-1.8] (20-180)	6-30 [0.4-2.0] (40-200)
Supply ¹ Pressure	psig [BAR] (kPa)	20-120 [1.5-8.0] (150-800)	32-120 [2.2-8.0] (220-800)	35-120 [2.4-8.0] (240-800)
Minimum Span	psig [BAR] (kPa)	5 [0.35] (35)	10 [0.7] (70)	10 [0.7] (70)
Impedance (OHMS) / Input Signal	4-20 mA 10-50 mA 0-5 VDC 0-10 VDC 1-5 VDC 1-9 VDC	197 79 550 1100 500 1000	204 82 532 1064 483 970	204 82 532 1064 483 970
Air Consumption (per ISA S51.1) SCFH		5.0 (.14m ³ /HR)	6.0 (.17m ³ /HR)	6.0 (.17m ³ /HR)

Supply Pressure Effect On Output 0.25 psig, [0.017 BAR], (1.7 kPa) for a 25 psig, [1.7 BAR], (170 kPa) supply change.

Flow Rate (SCFM) 2.5 (4.25m³/HR) @ 25 psig, [1.7 BAR], (170 kPa) Supply & 9 psig, [0.6 BAR], (60 kPa) Output.

9.0 (15.3 m³/HR) @ 120 psig, [8.0 BAR], (800 kPa) Supply & 9 psig, [0.6 BAR], (60 kPa) Output.

Temperature Range -20° F to +150° F (per ISA S51.1) (-30° C to +65° C)

2 Model T6000 Series

PERFORMANCE SPECIFICATIONS

Output Range	psig [BAR] (kPa)	3-15 [0.2-1.0] (20-200)	3-27 [0.2-1.8] (20-180)	6-30 [0.4-2.0] (40-200)
Independent Linearity (per ISA S51.1)		± 0.5% FS	± 0.5% FS	± 0.5% FS
Hysteresis & Repeatability (per ISA S51.1)		0.25% FS	0.25% FS	0.25% FS

RFI/EMI Effect Less than 0.5% of Span @ 30 ^v/M class 3 Band ABC (20-1000 mHz) per SAMA PMC 33.1 1978 and less than 0.5% of Span @ 10 ^v/M level 3, 27-500 mHz Band per IEC Standard 801-3 1984. EMC Directive 89/336/EEC European Norms EN50081-2 and EN 50082-2.

Materials of Construction

- Body and Housing Aluminum
- Orifice Nickel Plated Brass
- Trim Zinc Plated Steel
- Diaphragm Nitrile

¹ Supply Pressure must be no less than 5 psig, [0.35 BAR], (35 kPa) above maximum output.

OUTLINE DIMENSIONS

Model TT6000 Standard Range

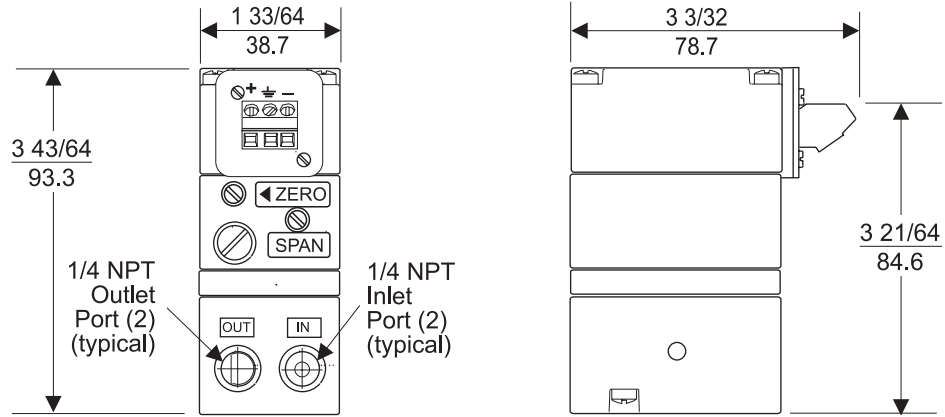

Figure 2. Model TT6000 Outline Dimensions.

Model TD6000 Standard Range

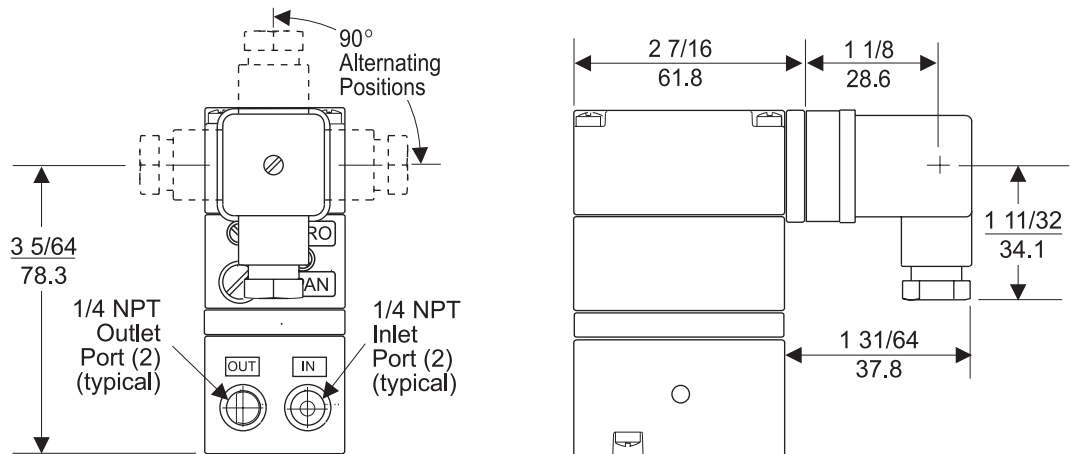

Figure 3. Model TD6000 Outline Dimensions.

Model TR6000 Standard Range

Note:
Model TR6000 Transducer is designed for use with the TR Rack Kit. Physically, it is the same as the TT6000 Unit except that the terminal block has been rotated to the rear.

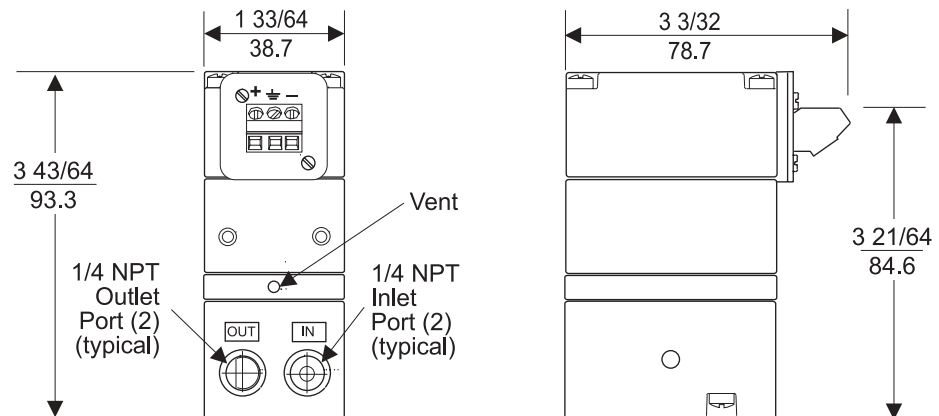

Figure 4. Model TR6000 Outline Dimensions.

OUTLINE DIMENSIONS

Model TA6000 Extended Range

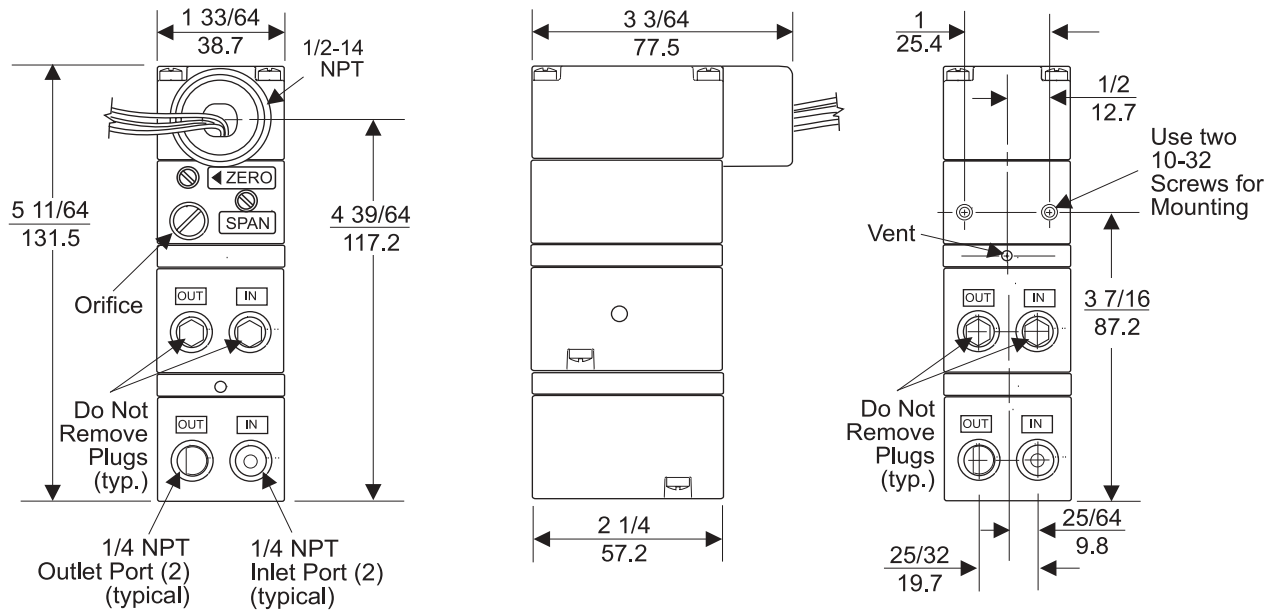

Figure 5. Model TA6000 Outline Dimensions.

EXTENDED RANGE SPECIFICATIONS

FUNCTIONAL SPECIFICATIONS

Output Range	psig [BAR] (kPa)	0-30 [0-2.0] (0-200)	0-60 [0-4.0] (0-400)	0-120 [0-8.0] (0-800)
Supply ¹ Pressure	psig [BAR] (kPa)	35-150 [2.5-10.0] (250-1000)	65-150 [4.6-10.0] (460-1000)	125-150 [8.8-10.0] (880-1000)
Minimum Span	psig [BAR] (kPa)	12 [0.8] (80)	25 [1.5] (150)	50 [3.5] (350)
Impedance (OHMS)/ Input Signal	4-20 mA 10-50 mA 0-5 VDC 0-10 VDC 1-5 VDC 1-9 VDC	250 100 439 878 400 800	256 103 469 938 453 750	270 108 446 893 430 714
Air Consumption (per ISA S51.1) SCFH		12.0 (.34m ³ /HR)	13.0 (.36m ³ /HR)	17.0 (.48m ³ /HR)
Supply Pressure Effect On Output	psig (BAR) (kPa)	0.5 (0.03) (4.0)	1.0 (0.07) (7.0)	5.5 (0.1) (10.5)
Flow Rate (SCFM)		11 (18.7 m ³ /HR) @ 150 psig, [10 BAR], (1000 kPa) Supply & 9 psig, [0.6 BAR] (60 kPa) Output.		

PERFORMANCE SPECIFICATIONS

Output Range	psig [BAR] (kPa)	0-30 [0-2.0] (0-200)	0-60 [0-4.0] (0-400)	0-120 [0-8.0] (0-800)
Independent Linearity (per ISA S51.1)		± 0.75% FS	± 1.0% FS	± 1.0% FS
Hysteresis & Repeatability (per ISA S51.1)		<1.0% FS @ 35 psig, [2.5 BAR], (250 kPa)	<1.0% FS @ 65 psig, [4.6 BAR], (460 kPa)	<1.0% FS @ 125 psig, [8.8 BAR], (880 kPa)
RFI/EMI Effect	Less than 0.5% of Span @ 30 ^v /M class 3 Band ABC (20-1000 mHz) per SAMA PMC 33.1 1978 and less than 0.5% of Span @ 10 ^v /M level 3, 27-500 mHz Band per IEC Stan- dard 801-3 1984. EMC Directive 89/336/ EEC European Norms EN 50081-2 and EN 50082-2.			
Materials of Construction	Body and Housing	Aluminum		
	Orifice	Nickel Plated Brass		
	Trim	Zinc Plated Steel		
	Diaphragm	Nitrile		

Temperature Range -20° F to +150° F
(per ISA S51.1) (-30° C to +65° C)

¹ Supply Pressure must be no less than 5 psig, [0.35 BAR],
(35 kPa) above maximum output.

OUTLINE DIMENSIONS

Model TT6000 Extended Range

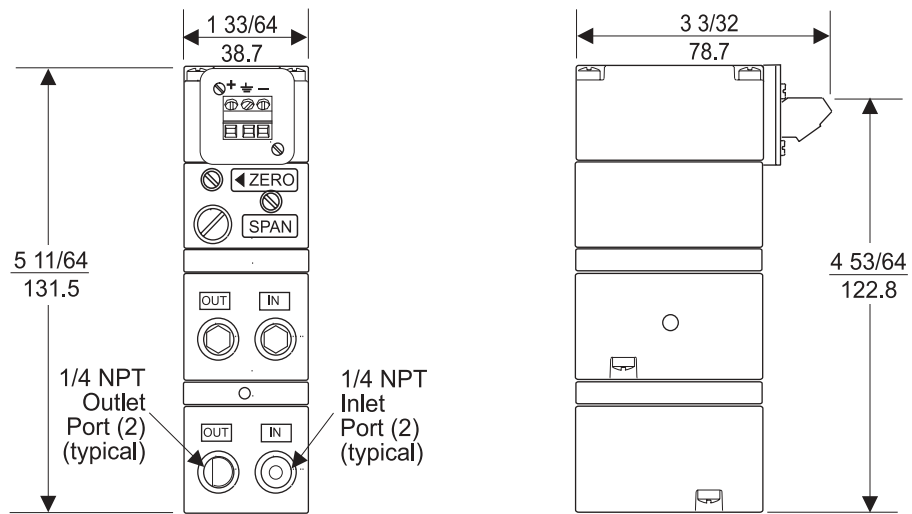

Figure 6. Model TT6000 Outline Dimensions.

Model TD6000 Extended Range

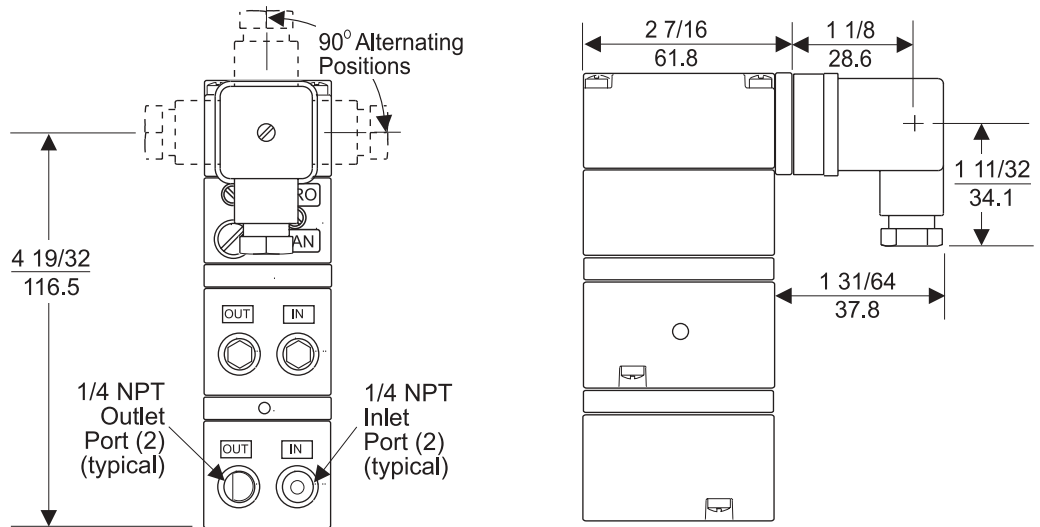

Figure 7. Model TD6000 Outline Dimensions.

Model TR6000 Extended Range

Note:
Model TR6000 Transducer is designed for use with the TR Rack Kit. Physically, it is the same as the TT6000 Unit except that the terminal block has been rotated to the rear.

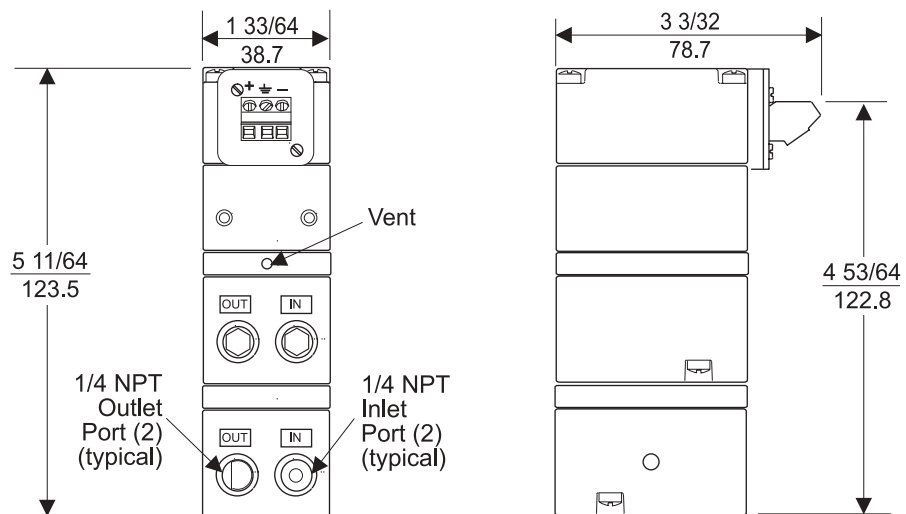

Figure 8. Model TR6000 Outline Dimensions.

OUTLINE DIMENSIONS

**Model T6000
Explosion-Proof**

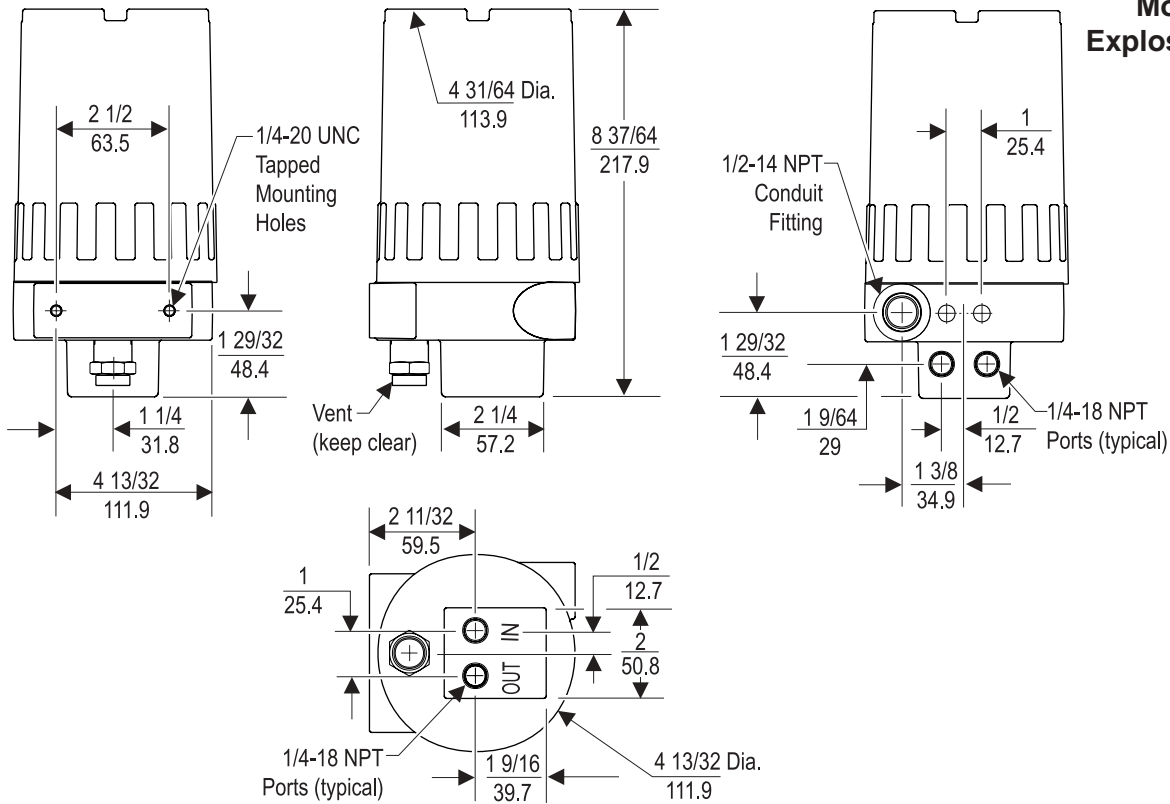

Figure 9. Explosion-Proof Outline Dimensions.

HAZARDOUS AREA SPECIFICATIONS

FM (Factory Mutual) Approvals:

Explosion-Proof:

Class I, Division 1, Groups B, C, and D;
Class II, Division 1, Groups E, F, and G;
NEMA 4X Enclosure.

Intrinsically Safe:

Class I, II, and III, Division 1, Groups A, B, C, D, E, F and G.

Entity Parameters	
$V_{max}^1 = 40 \text{ VDC}$	$C_i^3 = 0 \mu\text{F}$
$I_{max}^2 = 125 \text{ mA}$	$L_i^4 = 3 \text{ mH}$
¹ V_{max} = Maximum Voltage	³ C_i = Capacitance
² I_{max} = Maximum Current	⁴ L_i = Inductance

CSA (Canadian Standards Association) Approvals:

Explosion-Proof:

Class I, Division 1, Groups B, C, and D;
Class II, Division 1, Groups E, F, and G;
Type 4 Enclosure.

Intrinsically Safe:

Class I, Division 1, Groups A, B, C, and D;
Temperature Code T3C.
Rated 4-20 mA, 30 VDC Maximum.



Approvals are valid when connected through a Shunt Zener Diode Safety Barrier meeting the following parametric requirements:

System Type 1:	Single Channel Polarized Rated: 28V Max. 300 Ohm Min.
System Type 2:	Dual Channel Polarized Rated: 28V Max. 300 Ohm Min.
System Type 3:	a. 28V Max. 300 Ohm Min. & 10V Max. 50 Ohm Min. return. b. 28.5V Max. 300 Ohm Min. & 9V Max. 50 Ohm Min. return.

CENELEC Approvals:

Flame-Proof: (units rated 3-15 psig Only.)

EEx d IIB, T5 (65° C) Ambient;
IP65 Enclosure.

Intrinsically Safe:

EEx ia IIC, T4.

Certified Temperature Range:

-20° C to +65° C

NOTE: The Intrinsically Safe Approval is to the Harmonized European Directives.

Transducer Parameters	
$U_{max}^1 = 28 \text{ V}$	$W_{max}^3 = 0.653 \text{ W}$
$I_{max}^2 = 93 \text{ mA}$	$C_{eq}^4 = 0$
¹ U_{max} = Maximum Voltage	³ W_{max} = Maximum Power
² I_{max} = Maximum Current	⁴ C_{eq} = Capacitance

MOUNTING KITS

Mounting Kit EA-16799-1

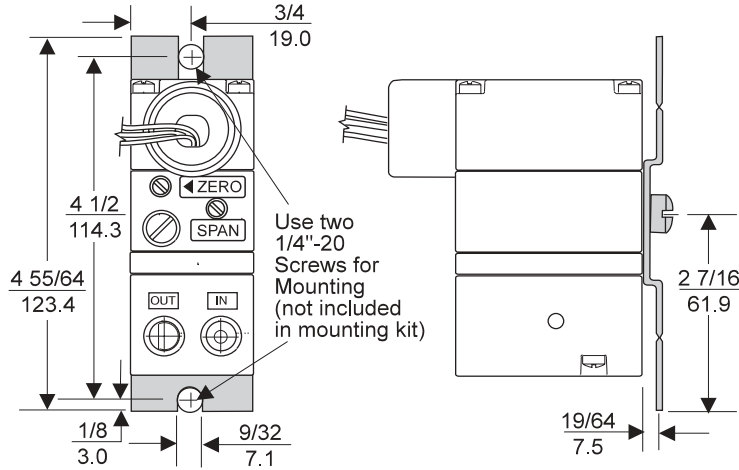

Panel / Wall Mounting Configuration shown with Model TA6000

See Note:

Note: Extended Range extends an additional 1 1/2" from bottom of Standard Range.

Figure 10. Mounting Kit EA-16799-1. (Included with Unit)

DIN Rail Mounting Kit EA-16893-1

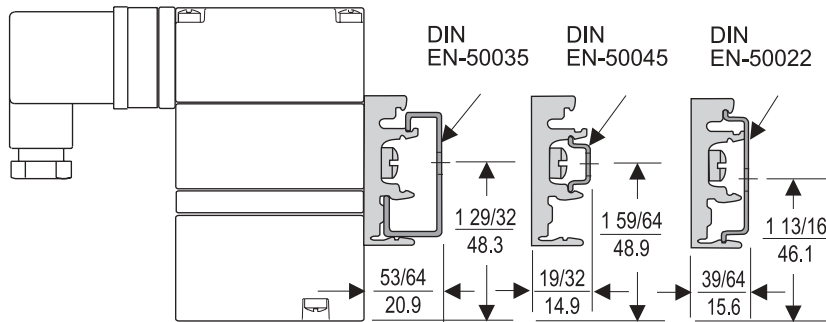

Din Rail Mounting Configuration shown with Model TD6000 & Din EN-50045

See Note:

Figure 11. Din Rail Mounting Kit EA-16893. (Included with Unit)

Mounting Kit EA-19254-1

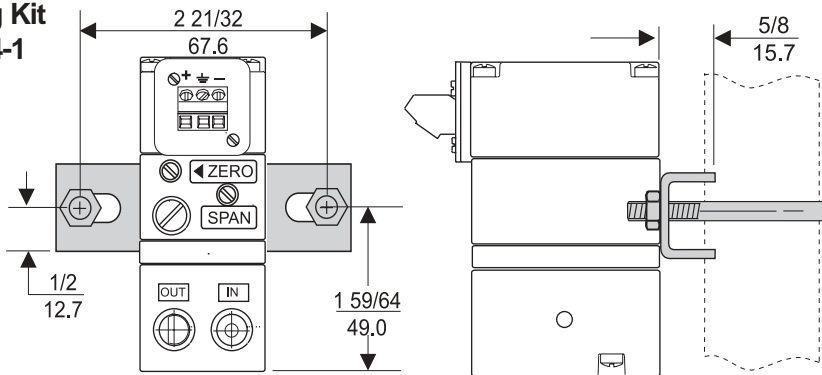

2" Pipe Mounting Configuration shown with Model TT6000

See Note:

Figure 12. Mounting Kit EA-19254-1. (Sold Separately)

Mounting Kit EA-18187-1

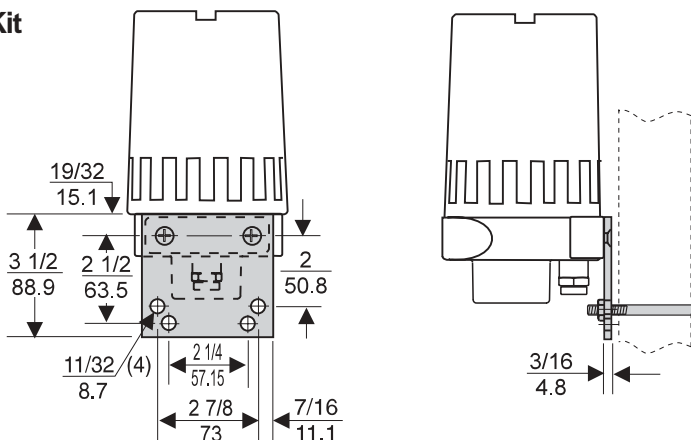

2" Pipe Mounting Configuration shown with Explosion-Proof

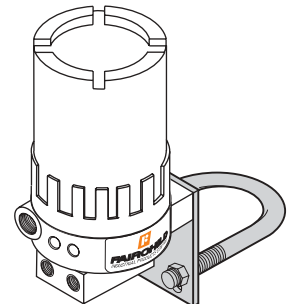

Figure 13. Mounting Kit EA-18187-1. (Sold Separately)

CROSS SECTION

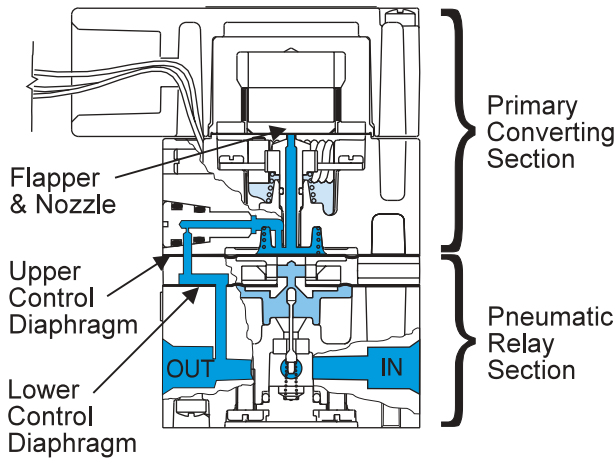

Figure 14. Model T6000 Standard Range

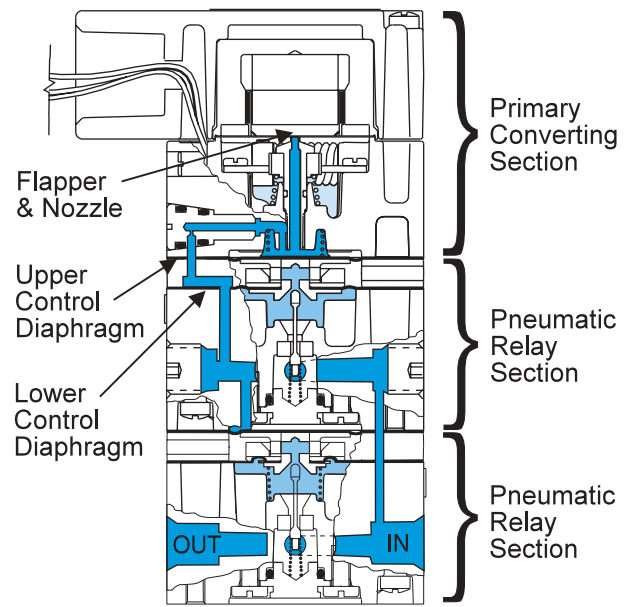

Figure 15. Model T6000 Extended Range

OPERATING PRINCIPLES

Standard Range

The T6000 Series is an electro-pneumatic device that converts a DC input signal to a pneumatic output. This device is made up of two sections, the Primary Converting Section and the Pneumatic Relay Section. The Coil and Suspension Spring, in the Primary Converting Section, is used as a Flapper. Together the Flapper and Nozzle work to control the signal pressure. The signal pressure acts on the Upper Control Diaphragm, in the Pneumatic Relay Section, which sets the output pressure. The output pressure is sensed by the Lower Control Diaphragm, in the Pneumatic Relay Section, which maintains the output pressure. For more information, see Figure 14. “Model T6000 Standard Range” above.

Explosion-Proof

The TX6000 Unit consists of a TT6000 Series Transducer enclosed in an Explosion-Proof/NEMA 4X (IP65) housing. For more information, see Figure 9. “Explosion-Proof Outline Dimensions” on page 6.

Extended Range

The Extended Unit is made up of three sections, the Primary Control Section, the Pneumatic Relay Section, and an additional Pneumatic Relay Section. The additional Relay Section is used to amplify the output pressure. For more information, see Figure 15. “Model T6000 Extended Range” above.

INSTALLATION

For Installation Instructions refer to the *Fairchild T6000 Standard Range/Explosion-Proof Electro-Pneumatic Transducer IOM, IS-50T6000S* and the *Fairchild T6000 Extended Range/Explosion-Proof Electro-Pneumatic Transducer IOM, IS-50T6000E*.

TYPICAL APPLICATION

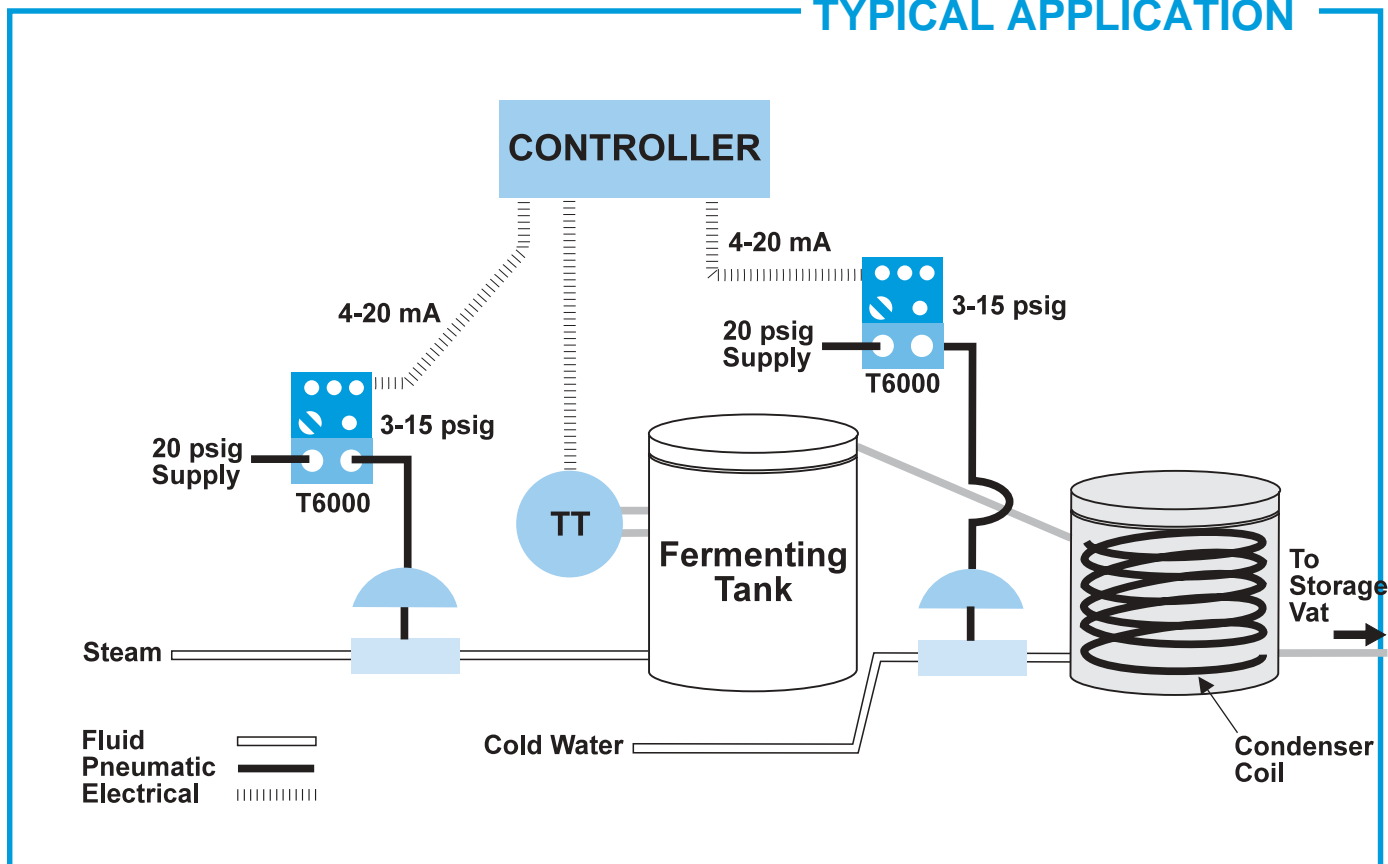
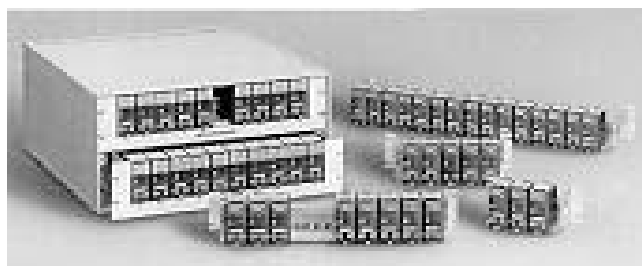

Figure 16. Distillation Process Application for the Model T6000 Series.

— TYPICAL APPLICATIONS —

The T6000 Series Transducer is used to control critical steam and cold water temperatures in a distilling operation. A controller provides an electronic signal to a T6000 Series Transducer, which supplies the appropriate output pressure to control the steam valve on a fermenting tank. A temperature transmitter on the fermenting tank provides a feedback signal to the controller to insure that the temperature of the tank is maintained very accurately. A second transducer is used on the cold water line to accurately control the condenser temperature. For more information, see Figure 16. "Distillation Process Application for the Model TA6000 Series" above.

— MANIFOLD/RACK MOUNTING —



Manifold/Rack Mounting Kits for the T6000 Series

Optional manifolds are available for mounting 3, 5, 10 or 15 transducers. An optional rack kit is available for mounting 10 transducers in a standard 19" rack. For information on Manifold and Rack mounting, refer to the *Fairchild Manifold and Rack Kit Catalog, CS-4000MRKT*.

— ORDERING INFORMATION —

Catalog Number T **6000-**

Electrical Connections

- 1/2 NPT Conduit (A)
- Fitting with Pigtail (T)
- Terminal Block (D)
- DIN 43650 Connection (R)
- Rack Mount ()
- Leave blank for explosion-proof ()

Underwriting Group

- Factory Mutual (F)
- Canadian Standard (C)
- CENELEC (E)

Approval Class

- Explosion-Proof & ¹ Dust Ignition-Proof (includes NEMA 4X/IP65) (XPD)
- Intrinsically Safe ² (I)
- None (leave blank) ()

Input

- 4-20mA (4)
- 10-50mA (3)
- 1-5 VDC (5)
- 0-5 VDC (7)
- 1-9 VDC (9)
- 0-10 VDC (0)

Output *Select appropriate psig, [BAR] or (kPa) range.*

- 3-15 psig (01)
- 3-27 psig (02)
- 6-30 psig (03)
- 0-30 psig (04)
- 0-60 psig (05)
- 0-120 psig (06)
- [0.2-1.0 BAR] (11)
- [0.2-1.8 BAR] (12)
- [0.4-2.0 BAR] (13)
- [0 - 2.0 BAR] (14)
- [0 - 4.0 BAR] (15)
- [0 - 8.0 BAR] (16)
- (20-100 kPa) (21)
- (20-180 kPa) (22)
- (40-200 kPa) (23)
- (0 - 200 kPa) (24)
- (0 - 400 kPa) (25)
- (0 -800 kPa) (26)

Options BSPT Thread (U)

¹ CENELEC Flame-Proof (explosion-proof) units are only available rated 3-15 psig, [0.2-1.0 BAR], (20-100 kPa) Output and 30 psig, [2.0 BAR], (200 kPa) Maximum Supply.

² Intrinsically Safe for Current Input Units Only.



FAIRCHILD
INDUSTRIAL PRODUCTS COMPANY

3920 WEST POINT BLVD. WINSTON-SALEM, NC 27103-6708
TEL 336-659-3400 FAX 336-659-9323

www.fairchildproducts.com



FM NO. 25571