

HOLLOW TYPE

NOC-HP Model



Heavy Duty Model 50mm Diameter Encoder (IP65)
 -Standard Versions of 10~10000 P/R, for High Accurate Application.



Model
NOC-HP [] [] - **2M** [] [] [] [] [] [] - [] [] [] [] [] [] **00E**

Style	Resolution	Output Mode	Hollow Shaft Diameter	Cable Length	Complying with RoHS
H: Hollow Shaft P: Dust-Proof & Water-Proof					
10	10P/R	600	600P/R		
20	20P/R	1000	1000P/R		
30	30P/R	1024	1024P/R		
40	40P/R	1250	1250P/R		
50	50P/R	1800	1800P/R		
60	60P/R	2000	2000P/R		
100	100P/R	2048	2048P/R		
200	200P/R	2500	2500P/R		
250	250P/R	3600	3600P/R		
300	300P/R	4096	4096P/R		
360	360P/R	5000	5000P/R		
500	500P/R	10000	10000P/R		

8 : φ8
 *9525 : φ9.525
 10 : φ10
 * Option

050 : 500mm (Standard)
 100 : 1000mm
 300 : 3000mm

No Indication : Other than D output
 No Indication : D output with LS
 C : D output with C-MOS

No Indication: Voltage Output
 C : Open Collector Output
 HC : Open Collector Output / High Voltage
 HCP : PNP Mode Open Collector Output / High Voltage
 HT : Push-Pull Output / High Voltage
 D : Line Driver Output
 WT : Push-Pull Output / Wide Voltage(10~2500P/R)

Signals — 2M: AB90° Phase Difference + Index Signal
 *10000 P/R (Line Driver Only)

External Dimension

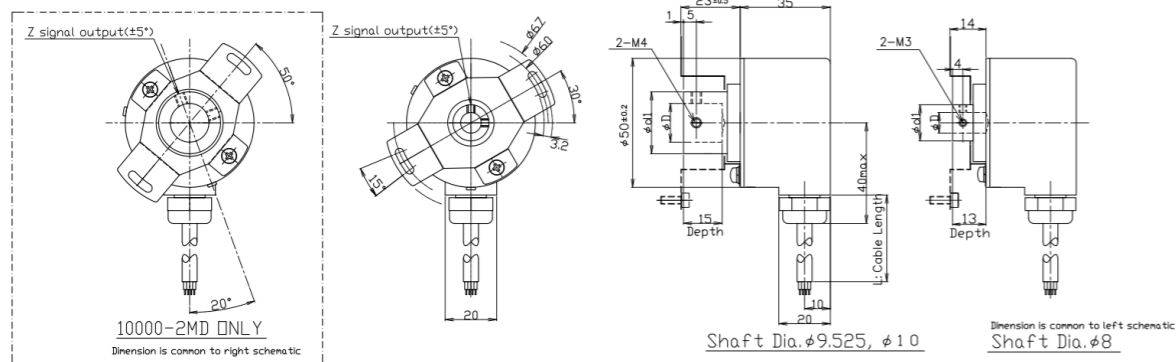

Setting Dimensions

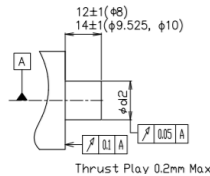

Shaft	φ0	φφ1	φφ2
5	φ8H7	φ1.4±0.2	φ8g6
9525	φ9.525H7	φ2.0±0.2	φ9.525g6
10	φ10H7	φ2.0±0.2	φ10g6

Electrical Connections

Model	Color	Signal	Color	Signal
2M	Red	Power Supply(Vcc)	White	Signal B
2MC	Black	0V	Gray	Signal B
2MHC	Green or Blue	Signal A	Yellow	Signal Z
2MHCP	White	Signal B	Orange	Signal Z
2MHT	Yellow	Signal Z		
2MWT	Shield	F·G		

Electrical Spec

TYPE	*1) at Maximum Sink Current				*2) Maximum Source Current		
	2M	2MC	2MHC	2MHCP	2MHT	2MD	2MWT
Power Supply(Vcc)	DC4.5~13.2 V			DC10.8~26.4 V		DC4.5~5.5V (C-MOS)	DC 4.75~30V
Current Consumption	90 mA Max	70 mA Max		100 mA Max	90 mA Max	70 mA Max (C-MOS)	60 mA Max
Output Voltage	"H"	Vcc-1V Min	—————		Vcc-1V Min	Vcc-3V Min	2.5 V Min
	"L" *1	0.5 V Max			—————	3 V Max	0.5 V Max
Maximum Sink Current	20 mA				40 mA	20 mA	30 mA
Rise & Fall Time	1 μs Max					200 ns Max	3 μs Max
Maximum Frequency Response	200 kHz			50 kHz	200 kHz (~5000P/R) 1 MHz (10000P/R)		100 kHz
Withstanding Voltage of Output Tr.	—————			50 V Max		—————	

Wave Form

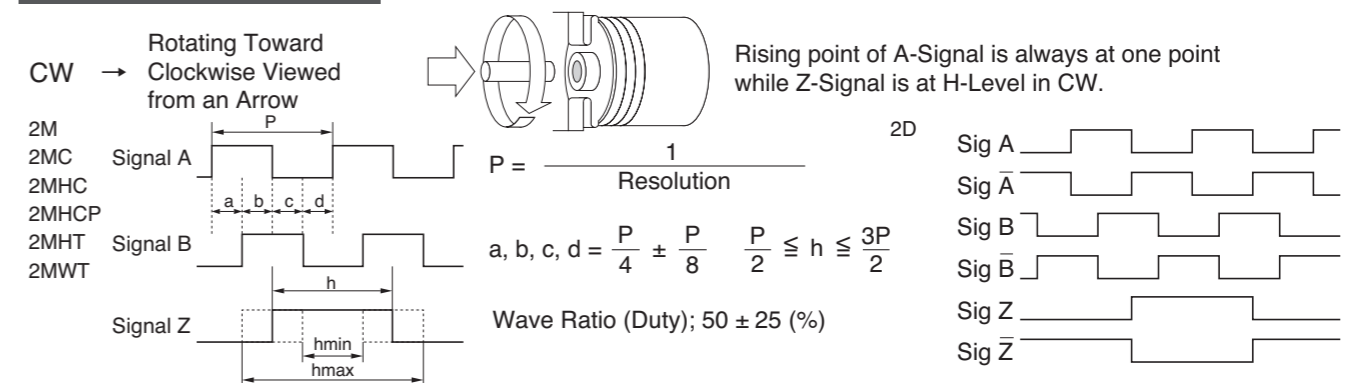

Output Circuit

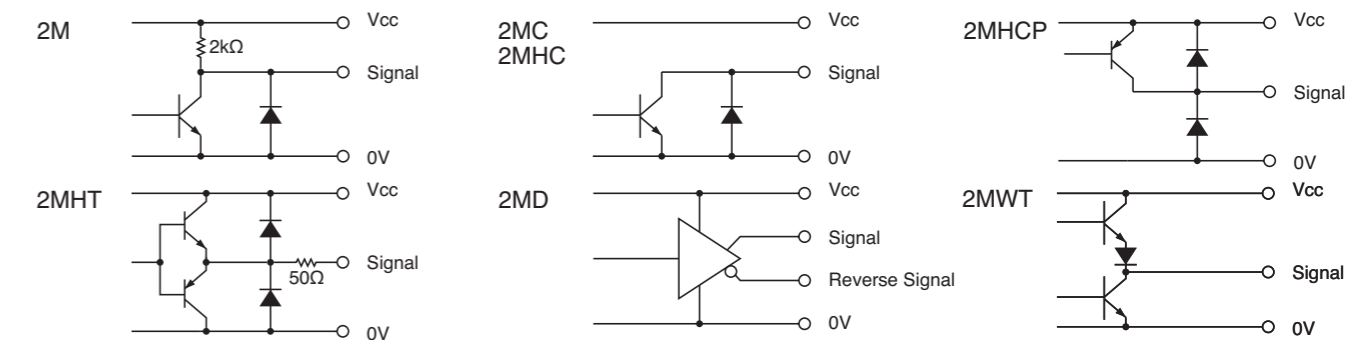

Mechanical Spec

Starting Torque	9.8×10 ⁻³ N · m Max
Angular Acceleration	1×10 ⁵ rad/s ²
Shaft Loading	Thrust: 49N
	Radial: 78.4N
Moment of Inertia	3×10 ⁻⁶ kg · m ²
Maximum Permissible Speed	Instantaneous : 5000min ⁻¹ Continuous : 3000min ⁻¹
Net Weight(Without Cable)	250g Max

Environmental Spec

Operating Temperature	-10°C~+70°C
Storage Temperature	-30°C~+85°C
Humidity	RH 85% Max No Condensation
Vibration	10~55 Hz / 1.5mm X,Y,Z Each 2h
Shock	980m/s ² , 11ms X, Y, Z Each 3 times
Ingress Protection	IP65